

FLW-B7

ARTICULATING WALL MOUNT ARM

SPECIFICATIONS

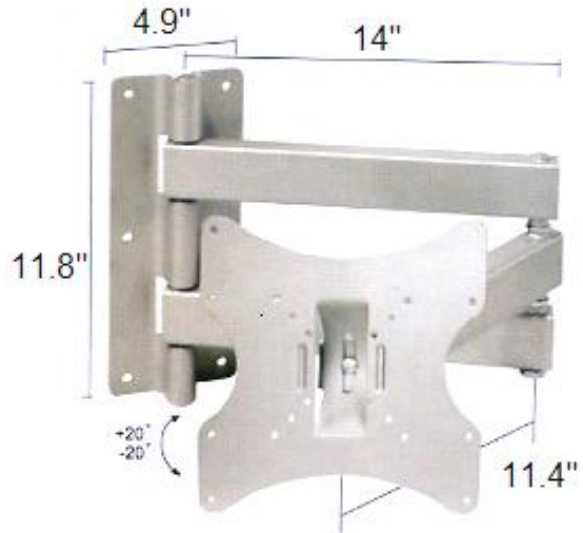
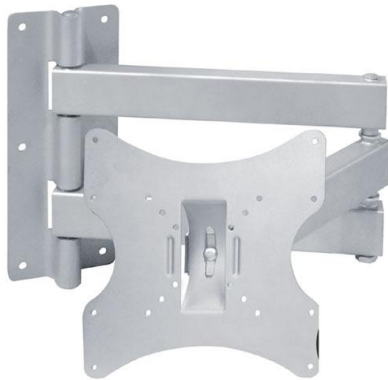

PRODUCT FEATURES

- FAST AND SIMPLE INSTALLATION
- FOR DISPLAYS 75/100mm /200mm VESA
- DISPLAY WEIGHT TO 60Lbs
- TILT TO 20 degrees UP/DOWN
- HARDWARE INCLUDED FOR WOOD/CONCRETE
- RUGGED SILVER POWDER COAT FINISH
- EXTENDS UP TO 25" FROM WALL
- STORE DISPLAY FLAT TO WALL WHEN FINISHED

INCLUDED WITHIN KIT

MOUNT WITH 75/100/200mmV ESA PLATE
COMPLETE PANEL ATTACHMENT HARDWARE
INSTALLATION GUIDE

CTN WGT 13.4Lbs
CTN DIM 17"x13"x2.5"

ARCHITECTURAL SPECIFICATIONS

The Flat Panel Wall Mount shall be FEC Model FLWB7 and shall be installed at all locations as listed per plans. Assembly and install shall be done according to the Manufacturer's install guide by a professional installation crew

Specifications subject to change without notice.